

HOLDERS and brushes for electromagnetic clutches

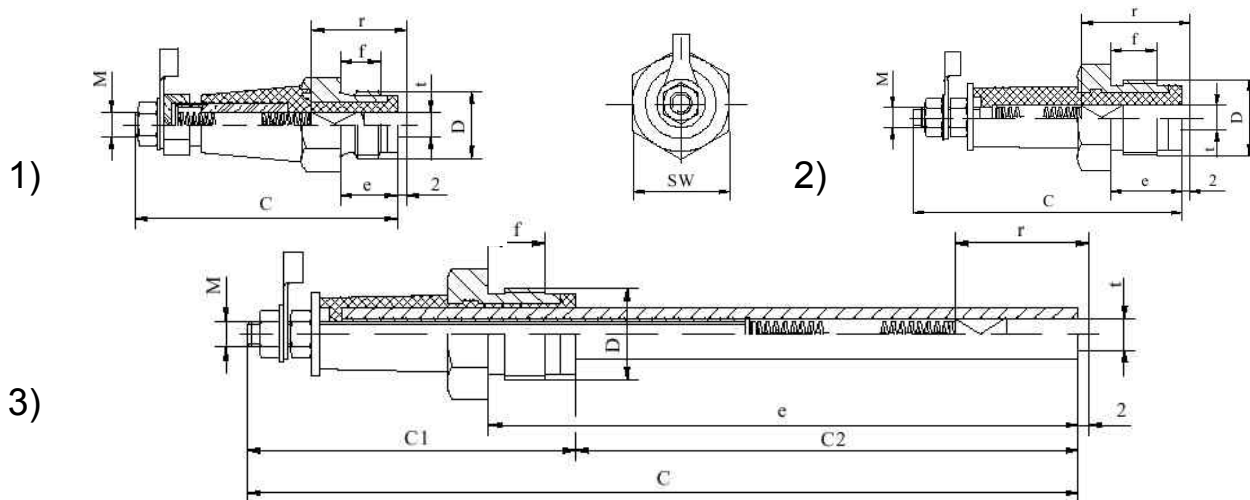

Order No.	Dim.	C	C1	C2	D	SW	e	f	M	Figure
RK 450-M14	Ø 4 x 20	50	-	-	M14x1,5	17	12	7	M4	1
RK 555-M14	Ø 5 x 20	55	-	-	M14x1,5	17	12	8,5	M5	1
RK 667-M16	Ø 6 x 26	67	-	-	M16x1,5	19	20	11	M5	2
RK 6145-M16	Ø 6 x 26	145	67	78	M16x1,5	19	98	11	M5	3
RK 664-M18	Ø 6 x 26	64	-	-	M18x1,5	22	17	11	M5	2
RK 666-M18	Ø 6 x 26	66	-	-	M18x1,5	22	19	11	M5	2
RK 6145-M18	Ø 6 x 26	145	64	81	M18x1,5	22	98	11	M5	3
RK 871-M18	Ø 8 x 30	71	-	-	M18x1,5	22	20	14	M5	2

Inserts / Brushes for dry application

Order No.	for	Dim.	Current	Periph.speed	Fig.
K1572	RK 450	Ø 4 x 20	2 (A)	40 (m/s)	4
M124/1	RK 555	Ø 5 x 20	4 (A)	40 (m/s)	5
K2371	RK667	Ø 6 x 26	4 (A)	40 (m/s)	6
	RK666				
	RK664				
K1573	RK6145	Ø 6 x 26	4 (A)	40 (m/s)	8
K1495	RK871	Ø 8 x 30	10 (A)	30 (m/s)	7

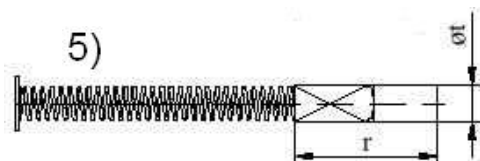
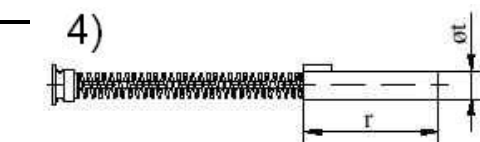

Inserts / Brushes for wet application (oil)

Order No.	for	Dim.	Current	Periph.speed	Fig.
M106/1	RK 450	Ø 4 x 20	3 (A)	20 (m/s)	4
M124	RK 555	Ø 5 x 20	6 (A)	20 (m/s)	5
M128/2	RK667	Ø 6 x 26	6 (A)	20 (m/s)	6
	RK666				
	RK664				
M119	RK6145	Ø 6 x 26	6 (A)	20 (m/s)	8

