

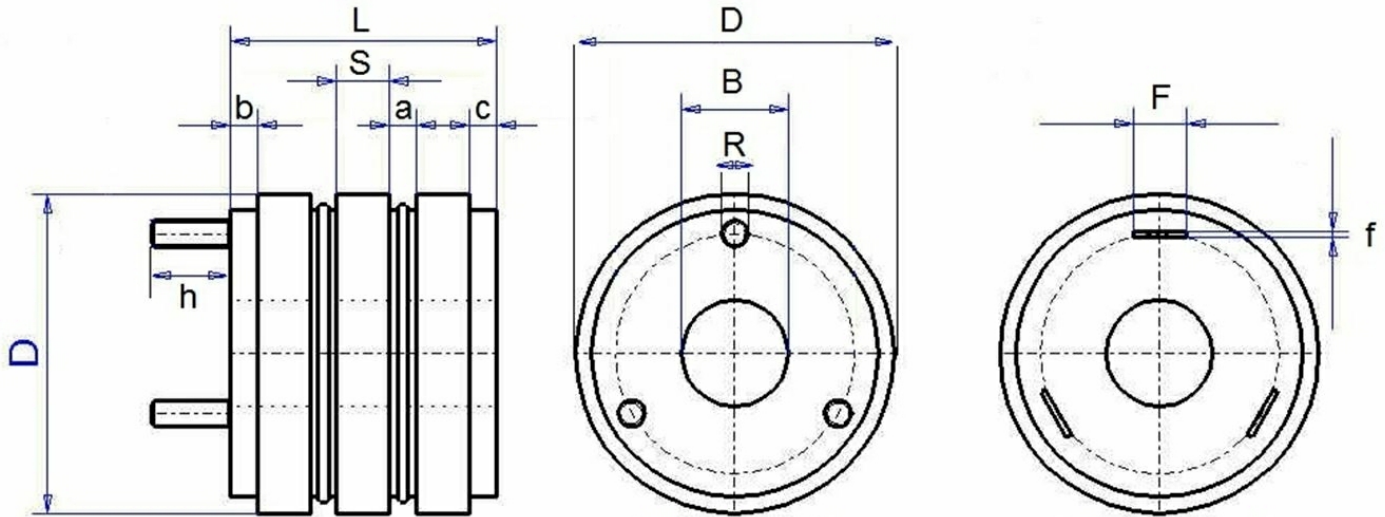

Please download this sheet and fill in the data.
Send the completed document to our email.

Order sheet for sliprings



Style 1

Style 2

- | | | | |
|--|------------|--------------|----|
| 1. No. of rings | Fabricate: | | |
| 2. Dim.: D | mm | | |
| 3. Dim.: S | mm | | |
| 4. Dim.: B | mm | | |
| 5. Dim.: L | mm | | |
| 6. Dim.: a | Dim.: b | Dim.: c | mm |
| 7. Dim.: R | mm | | |
| 8. Dim.: F | mm | | |
| 9. Dim.: f | mm | | |
| 10. Dim.: h | mm | 11. U/min.: | |
| 12. Amps per ring: | A | 13. Voltage: | V |
| 14. Dimension of brushes: | | | mm |
| 15. Additional information (key way, ring material, etc.): | | | |