

## Single-leg slipping brush-holders

Brush holder arms are brass, clamping pieces are extruded brass.  
 For peripheral speeds up to 15 m/s.

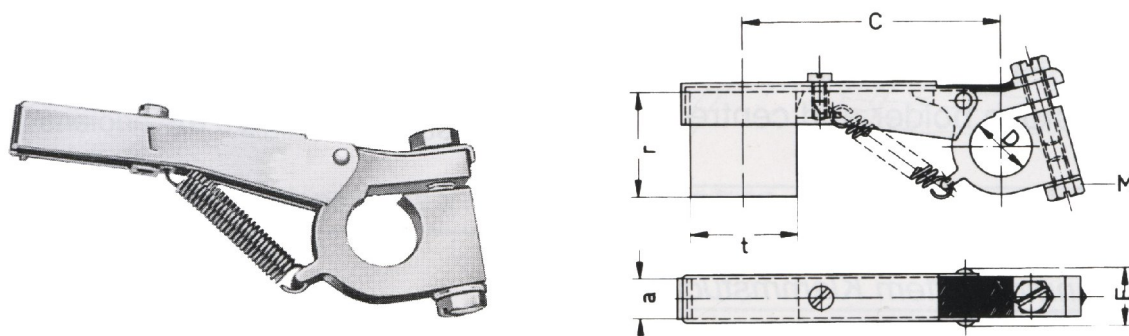

Order No.	Brush dimensions			C	Bore		Width E	Terminal M
	t	a	r		D	up to		
84 D 30-7	8	4	16	30	7	8	7,5	M3
85 D 30-7	8	5	16	30	7	8	8,5	M3
105 D 38-7	10	5	16	38	7	8	8,5	M3
126 D 36-10	12	6,3	20	36	10	13	10,5	M4
128 D 40-10	12	8	25	40	10	13	12	M4
168 D 44-10	16	8	25	44	10	13	12	M4
168 D 50-13	16	8	25	50	13	16	12	M4
208 D 50-13	20	8	25	50	13	16	12	M4
208 D 60-13	20	8	25	60	13	16	12	M4
2010 D 60-13	20	10	25	60	13	16	14	M5
2510 D 70-16	25	10	32	70	16	20	15	M5
2512 D 70-16	25	12,5	32	70	16	20	17,5	M6
3212 D 80-16	32	12,5	32	80	16	20	17,5	M6
3216 D 100-16	32	16	32	100	16	20	22	M6

Should you need a different type of brush-holder please indicate the following data:

Brush dimensions in mm: (txaxr) \_\_\_\_\_

Dimension C in mm: \_\_\_\_\_

Bore D in mm: \_\_\_\_\_

Width E in mm: \_\_\_\_\_

All dimensions are given in mm